



S11BP Subwoofer



70V / 100W Toroidal Transformer

## S11BP-70V | S11BP-8ohm

### Description

Ambisonic's S11BP-70V in-ground subwoofer is a powerhouse of clean, tight bass that perfectly compliments our satellite loudspeakers for true outdoor distributed audio. Designed to be partially buried or as a hardscape installation. Our proprietary 11" driver is an 8Ω, dual voice coil with a frequency response of 41Hz - 150Hz. Robust composite enclosure and powder coated canopy for "All Weather" outdoor installations.

High-performance custom built 70 Volt 100 Watt Toroidal Transformers with low insertion loss and linear response for use when long wire runs or distributed audio is a requirement. The ported composite enclosure as well as all components are designed to withstand the harshest of environmental conditions in any permanent outdoor installation.

The S11BP-70V Subwoofer delivers the punch, impact and clean tight bass necessary for outdoor installations. The S11BP-70V is designed to be the perfect companion to our 6.5HD-AW-L high definition loudspeakers, delivering the ultimate in "High Definition" audio for any outdoor environment. Backyard landscapes, patio and pool areas will come alive with unparalleled clarity and detailed sound, engineered to give you years of satisfaction and listening pleasure.

### Highlights

- 1 • Integrated 61.5 Oz Y35 Ferrite Magnet
- 2 • Waterproof Composite Cone
- 3 • Large Rubber Surround
- 4 • 70 Volt/100 Watt Toroidal Transformer (to be installed separately, buried ideally within 3 feet of subwoofer).



## Line Drawings

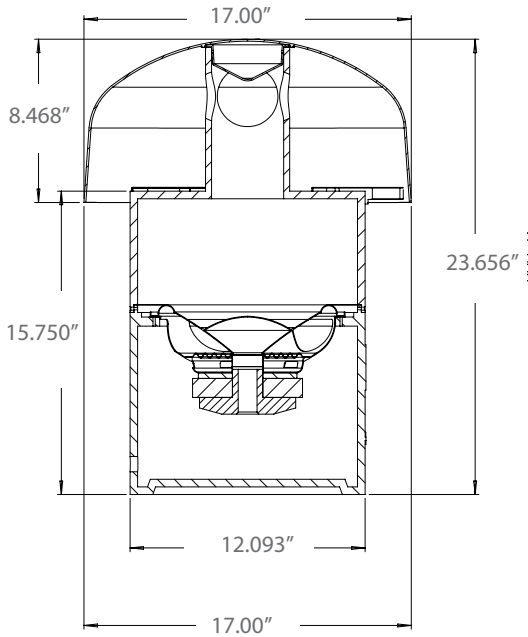

## Features

- 11" Dual Voice Coil Band-Pass In-Ground Subwoofer
- Robust Composite Roto-Mold Enclosure IP-65 per IEC529
- Polypropylene Cone
- Santoprene Rubber Surround
- 2" Voice Coil
- 61.5 Oz Y35 Ferrite Magnet
- 17" Diameter Dark Brown Textured Canopy
- Low Density Polyethylene (LDPE) Black Roto-Mold Sealed Enclosure
- 12dB Crossover Network (x2)
- Direct Burial 70 Volt 100 Watt Custom Toroidal Transformer included with the S11BP-70V Subwoofer
- Convenient Handles

## Specifications

SPECIFICATIONS	S11BP-70V / S11BP-80HM SUBWOOFER
System Type	Vertical Pass Subwoofer
Driver Components	11" All Weather Dual Voice Coil Polypropylene Woofer
Frequency Response	41Hz – 150Hz (+/- 3dB)
Max SPL @ 1m	113dB Continuous, 119dB Peak
Sensitivity, 1m/2.83V	90dB
Power Handling	200W x 2 AES 400W X 2 Peak
Input Connectors	Pigtail with Waterproof Wire Nuts
Enclosure	All weather, molded composite
Installation	In-Ground, Recommended Depth 9" (22cm) (leave 6" or 15 cm gap under canopy)
Transformer (S11BP-70V)	In-Ground 2 X 70V 100W (JB2100 Transformer)
Dimensions	12.20" Diameter x 23" H (Enclosure) 17" Diameter x 8.40" H (Canopy)
Shipping Weight	46.3lbs

\*All product specifications are subject to change. Please refer to [ambisonicsystems.com](http://ambisonicsystems.com) for latest information.