



12BP-IG-70V • 12BP-IG-8ohm

SPECIFICATIONS

System Type
 Driver Components
 Crossover
 Frequency Response
 Max SPL @ 1m
 Sensitivity, 1m/2.83V
 Power Handling
 Recommended Amp Power
 Rated Impedance
 Input Connectors
 Enclosure
 Optional Part
 Dimensions (H x W x D)
 Weight, Net/Shipping
 Warranty

12BP-IG-70V • 12BP-IG-8ohm SUBWOOFER

Band-pass Parallel Double Tuned In-Ground Subwoofer
 All Weather 12" Long Throw Woofer
 Recommended HPF = 30Hz 12dB per Octave Butterworth
 28Hz – 140Hz | 36Hz – 140Hz +/- 3dB
 123dB Continuous, 127dB Peak
 93dB
 1000W RMS, 2500W Peak, Displacement Limited
 300W (FTC) (12BP-IG-70V)
 1000W – 2000W (12BP-IG-8ohm)
 70V (10BP-IG-70V) | 8 Ω (10BP-IG-8ohm)
 24" x 16 AWG Pigtail with Waterproof Wire Nuts
 Composite Roto-Mold
 In-Ground 300W 70V Transformer (Part #JB1300) (12BP-IG-70V)
 34.5" x 21.625" x 18.875" | 87.5cm x 65cm x 47.9cm
 60Lbs (27.2Kg) | 67Lbs (30.4Kg)
 Limited 5 Year Warranty

*All product specifications are subject to change. Please refer to ambisonicsystems.com for latest information.



Scan the QR Code for full instructions for this product.

80hm Wiring



Includes a pair of silicon filled wire nuts for the connection

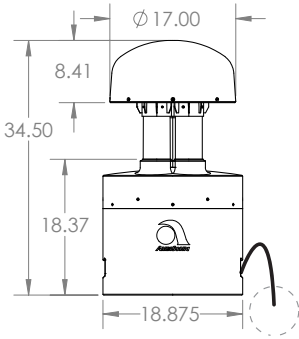

RED wire is positive
BLACK wire is negative

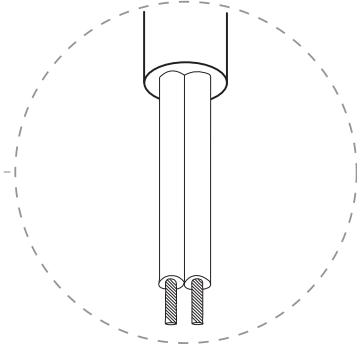

70V Wiring (Using JB1300)

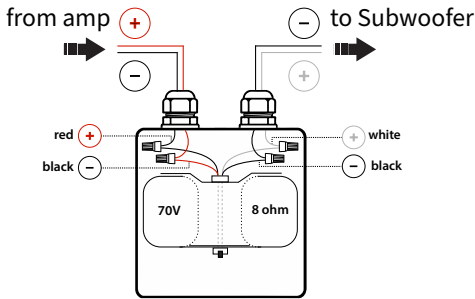

TECHNICAL ASSISTANCE

Please refer to ambisonicsystems.com for the full installation guidelines. If you have any questions or concerns about installing or using this product, you can reach us through one of the following methods:

Phone: (844) 674 - 4461

Hours of operation: 8:00am - 5:00pm (Pacific Time), Mon - Fri

Email: sales@originacoustics.com



05-03-24

6975 S Decatur Blvd, Las Vegas, NV 89118 • www.ambisonicsystems.com • 844-674-4461 • info@ambisonicsystems.com

©2024 Ambisonic Systems. All copyrighted, trademarked and patented elements mentioned herein are the sole property of Ambisonic Systems.