



ALSB106RD | ALSB106SQ

AMBISONIC BOLLARD 10 INSTALLATION MANUAL



Table of Contents

1.	Introduction	1
2.	Models & Specifications	4
3.	Included Items	5
4.	Required Tools	6
5.	Bollard Unit Assembly	6
5A.	Mid-range/Tweeter Port Tube Assembly	6
5B.	Adding Sealant, before Sleeve Assembly	9
5C.	Round Sleeve Assembly	9
5D.	Square Sleeve Assembly	11
6.	System Layout	14
7.	Installation Guidance	14
8.	Location of the Tap Setting Switch	18
9.	70V vs 8 Ω Wiring Options	18
10.	70V Wiring Setup: Installation Guidance	19
10A.	Mono 70V Wiring with D3200 Amp [2 Channel Setup]	22
10B.	Stereo 70V Wiring with D3200 Amp [3 Channel Setup]	23
10C.	Stereo 70V Wiring with D3200 Amp [3 Channel Setup]	24
11.	8 Ω Wiring Setup: Installation Guidance	25
11a.	8 Ω Wiring with D3200 Amp (1 Bollard Pair Only)	26
11b.	8 Ω Wiring with DSP3-700 Amp (1 Bollard Pair Only)	27
12.	Note: Painting the Sleeve	27
13.	Troubleshooting	28
14.	Technical Assistance	29
15.	Limited 5 Year Warranty	30
16.	Return Process	31

1. INTRODUCTION

Congratulations on selecting one of the finest outdoor speaker systems ever produced.

The Ambisonic Bollard is a single unit that houses both a subwoofer and a mid/high frequency satellite in the same enclosure. The speaker is designed to allow the subwoofer section to be buried in the ground leaving only the pillar section exposed. The sound from both the subwoofer & satellite emanate from the slots in the upper portion of the pillar section creating a uniform, full frequency sonic experience.

At Ambisonic, we take pride in providing you with a high quality product, all speakers are designed to have excellent sound quality, longevity, and a simple installation process.

This instruction booklet covers the necessary information for a smooth installation, including: the tools you will need, step-by-step instructions for installation, troubleshooting tips for any errors that may occur, and all warranty information.

If for any reason you experience problems or if you have installation questions please call us at (844) 674-4461. Hours of operation are 8:00am to 5:00pm (PacificTime), Monday through Friday.

2. MODELS & SPECIFICATIONS

ROUND SLEEVE:

- ALSB106RD-Black360
- ALSB106RD-Black180
- ALSB106RD-Silver360
- ALSB106RD-Silver180
- ALSB106RD-Bronze360
- ALSB106RD-Bronze180

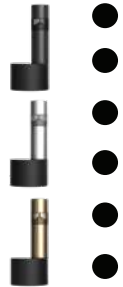

Sleeve Color	Sound Dispersion
Black	360°
Black	180°
Silver	360°
Silver	180°
Bronze	360°
Bronze	180°

SQUARE SLEEVE:

- ALSB106SQ-Black360
- ALSB106SQ-Black180
- ALSB106SQ-Silver360
- ALSB106SQ-Silver180
- ALSB106SQ-Bronze360
- ALSB106SQ-Bronze180



Sleeve Color	Sound Dispersion
Black	360°
Black	180°
Silver	360°
Silver	180°
Bronze	360°
Bronze	180°

MODEL	ALSB106RD/ ALSB106SQ
Woofer	10" Polypropolyne Woofer
Midrange	6.5" Polypropolyne Woofer
Tweeter	1" HD Ribbon Tweeter
Frequency Response	32HZ - 20KHZ
Power RMS	100W
Power Peak	300W
Impedance	8 Ohm (Sub) / 8 Ohm (Sat)
Transformer Taps	Selectable 8 Ω, 100W, 50W, (70V)
Subwoofer Diameter	17 23/32" (450mm)
Mounting Depth	9 9/16" (243mm)
Satellite Diameter	7 7/8" (200mm) - Round / 8 17/64" (210mm) -Square
Sleeve Height	27 3/32" (693mm)
Total Height	36 27/32" (936mm)
Enclosure Material	Poly Composite, Weather Resistant Enclosure

3. INCLUDED ITEMS

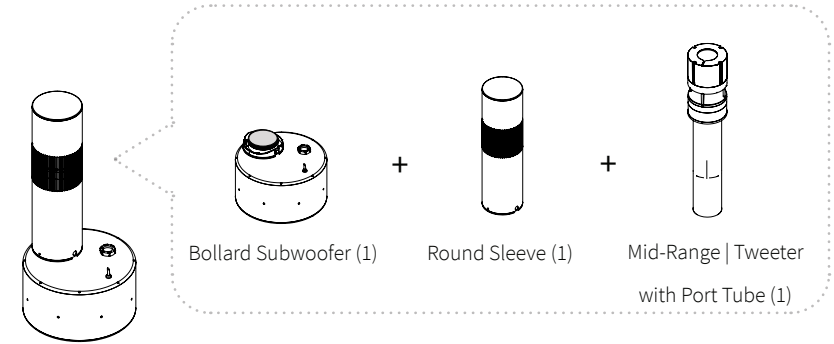

Round Sleeve Bollard (1)

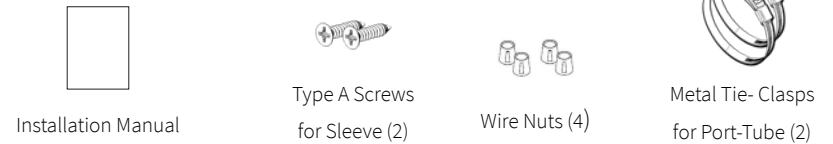

- or -

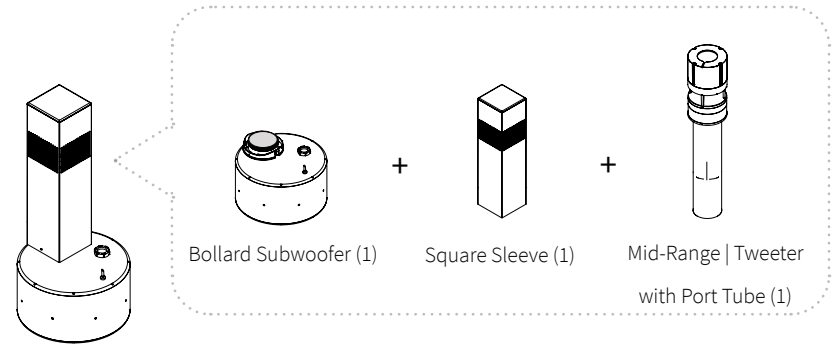

Square Sleeve Bollard (1)

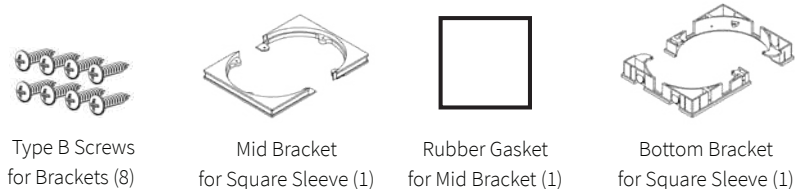
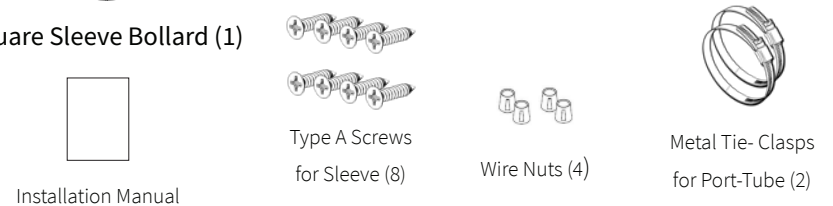

*All product specifications are subject to change. Please refer to ambisonicsystems.com for latest information.

4. REQUIRED TOOLS

- Flat Head Screwdriver
- Phillips Screwdriver [Min 10" Length] OR Electrical Drill with Elbow Attachment
- Shovel

5A. BOLLARD UNIT ASSEMBLY

The Bollard comes in two individual packages;

- 1) Subwoofer
- 2) Mid-Range/Tweeter with Port-Tube and Sleeve

To assemble these, it will depend on which shape of sleeve you have purchased.

To change the power tap setting, use the tap switch under the cap on the subwoofer. Ensure this selection is done before assembly & subwoofer burial.

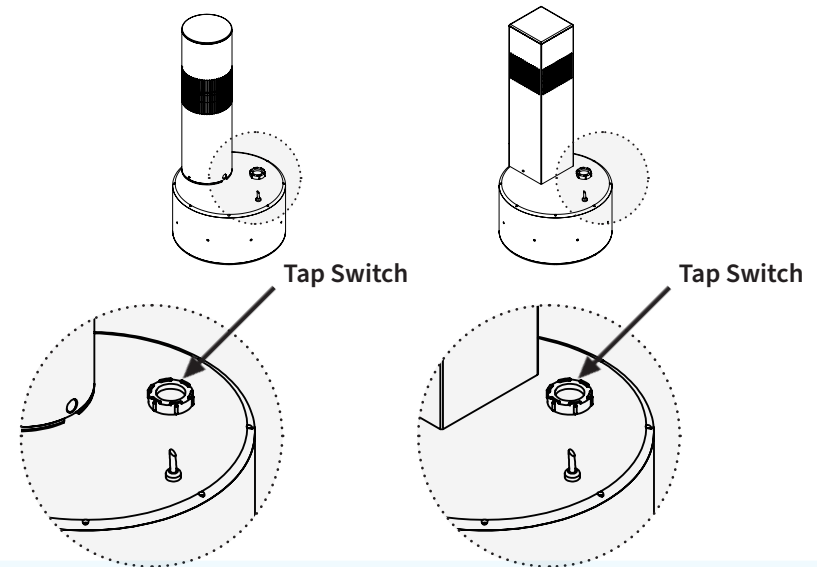

5B. LOCATION OF THE TAP SETTING SWITCH

Each Bollard speaker comes with a wire pigtail connecting into the subwoofer and satellite units of Bollard speaker, and each wire pair is labeled as **SUB IN** and **SAT IN** respectively.

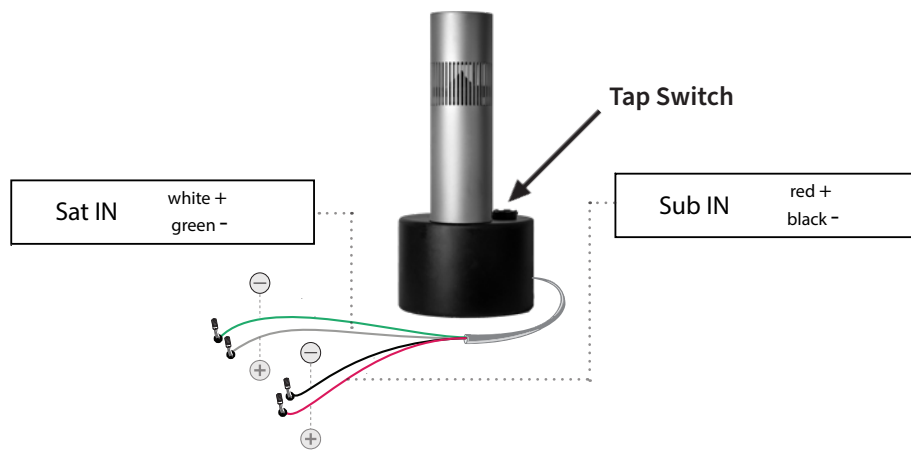

5C. MID-RANGE/TWEETER PORT-TUBE ASSEMBLY

Secure the Mid-Range/Tweeter Port-Tube into the Port Hole of the Subwoofer, by lining up the **VERTICAL Silver Line markings** with the protruding vertical “Dimple Line” on the rubber trim surrounding the Port Hole edges. If needed, you may hold the piece by the Port Tube, and twist back & forth (**DO NOT PUSH DOWN VERTICALLY**), so that it slides in smoothly into the Port Hole. Once aligned, it will slide down the Port Hole until the **HORIZONTAL Silver Line markings** meet the **VERTICALLY EXTRUDED RUBBER TRIM** on the Port Hole edge.

(See Diagram 5C • STEPS 1 | 2 | 3 • Page 8)

Then, use a Flat-Head Screwdriver to secure the Port-Tube in place by tightening the 2 Metal Tie-Clasps around the base of the Port Hole on the Subwoofer. (See Diagram 5C • STEP 4 • Page 9). Lastly, the Speaker Cable protruding from the Subwoofer can be connected with the Speaker Cable from the the Mid-Range/Tweeter. (See Diagram 5C • STEP 5 • Page 9)

DIAGRAM 5C. MID-RANGE/ TWEETER PORT-TUBE ASSEMBLY

PORT-TUBE ALIGNMENT

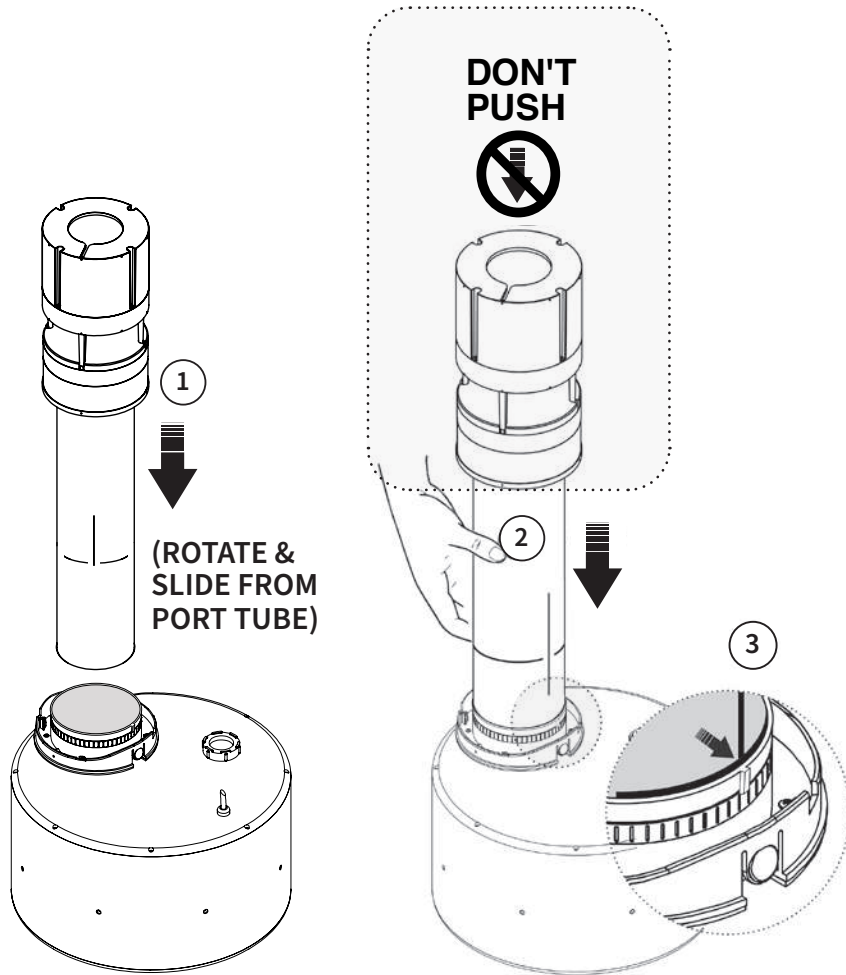

2 **DO NOT PUSH DOWN ON MID-RANGE/TWEETER MODULE. ONLY SLIDE DOWNWARDS FROM PORT TUBE, WITH CARE.**

3 **IN THE FULLY INSERTED POSITION, THE HORIZONTAL SILVER LINE MARKING WILL ALIGN ALONG THE EXTRUDED RUBBER TRIM SURROUNDING THE PORT HOLE, REMAINING VISIBLE. (DO NOT PUSH IN FURTHER)**

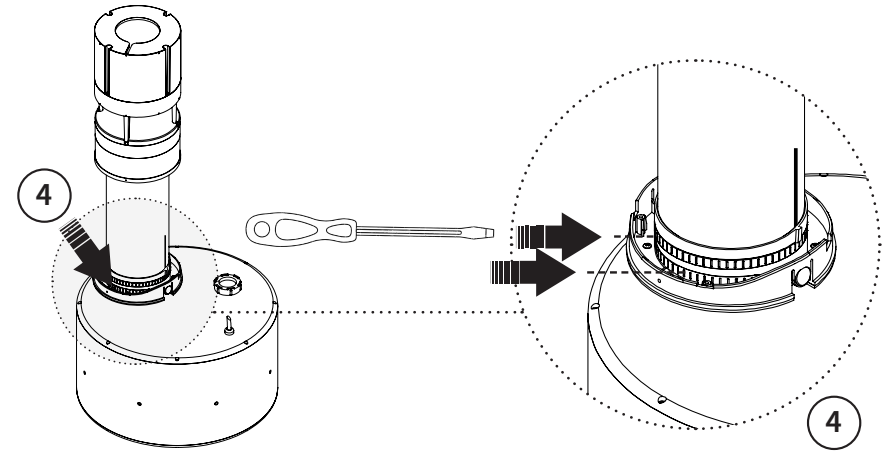

5 **CABLE CONNECTION**

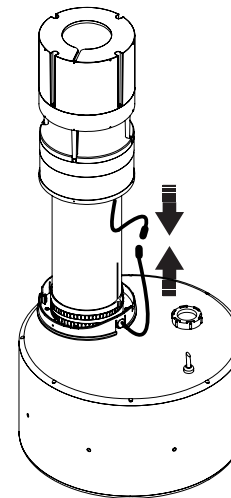

5D. ADDING SEALANT, BEFORE SLEEVE ASSEMBLY

Polyurethane Sealant: It is strongly recommended that Polyurethane Sealant be applied between the Sleeve & the Subwoofer Base. Care should be taken to apply a liberal 1/4" bead of Polyurethane Sealant along the Port Tube Base of the Subwoofer, before assembling the sleeve over the Port Tube. On each Bollard, this bead will lay on the outer edge surrounding the Round/Square Bottom Bracket. Ensure that the caulking sealant is fully cured, before burying the sub. This will improve weather resistance.

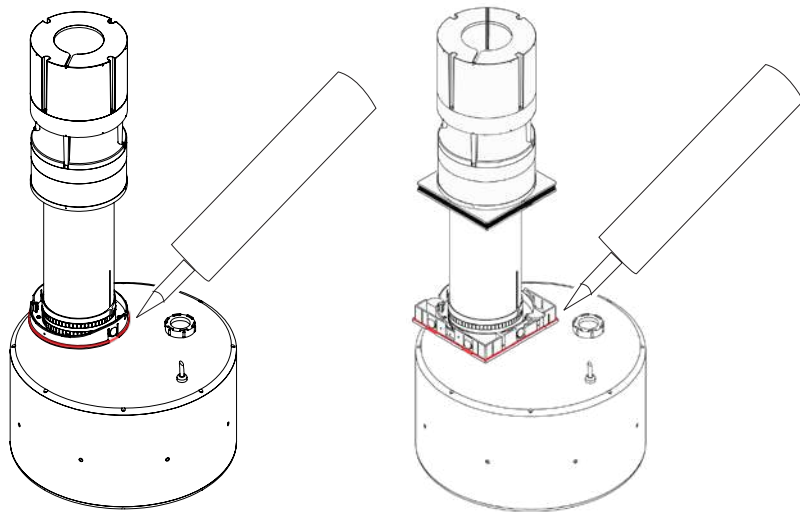

5E. ROUND SLEEVE ASSEMBLY

See Diagram 5B above, on adding Polyurethane Sealant, as recommended.

Now, the Round Sleeve should slide smoothly over the Mid-Range/Tweeter Port Tube, into the Port Hole Base. Ensure the 2 punched holes at the bottom of the sleeve align with the 2 round grooves, (Snap-Fit Latches), on the base of the Port Hole on the Subwoofer. Once the sleeve slides down far enough, the 2 Snap-Fit Latches will snap & grip the sleeve. Now, use the 2 Type A Screws (Phillips Flat Head), included in the packaging, with a Phillips screw driver to secure the sleeve to the structure. **(See Diagram 5E • STEPS 1 | 2 | 3 | 4 • Page 11).**

DIAGRAM 5E: ROUND SLEEVE ASSEMBLY

5E. SLEEVE ASSEMBLY WITH SNAP FIT LATCHES

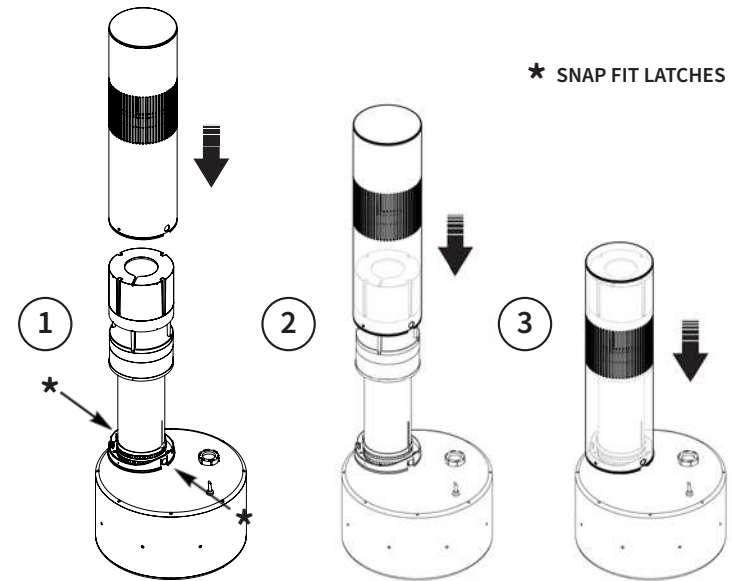

SLEEVE ASSEMBLY WITH SCREWS

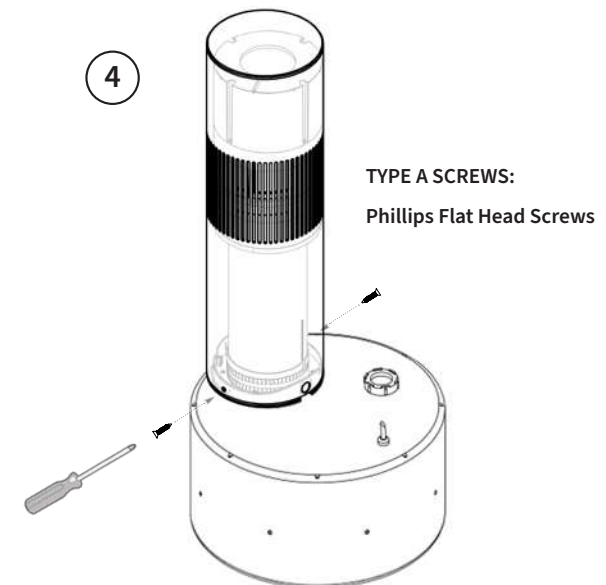

5F. SQUARE SLEEVE ASSEMBLY

The Square Bollard requires 2 adapter brackets to assemble the Square Sleeve over the Mid-Range/Tweeter Port Tube, and secure it to the Subwoofer base.

Firstly, the Mid Bracket will be placed at the mid-length of the Port Tube unit, just below the Mid-Range/Tweeter section. Attach the 2 halves of the Mid Bracket to this upper section of the Port Tube (See Diagram 5F • STEPS 1 | 2 • Page 13). The two Mid Bracket halves should fit snugly together around the Port Tube, just below the Mid-Range/Tweeter section. Secure the Mid Bracket halves to this upper section of the Port Tube, by inserting 4 Type B Screws (Phillips Pan Head), into the screw holes on the bottom of the bracket. Using 1 screw to connect each side of the bracket, tighten the 4 screws upwards into the upper section of the Mid-range/Tweeter Port Tube (See Diagram 5F • STEP 2 • Page 13). Once screwed into place, install the included Rubber Gasket, around the Mid Bracket (See Diagram 5F • STEPS 3 | 4 • Page 13).

Next, the Bottom Bracket will be placed at the bottom of the Mid-Range/Tweeter Port Tube (See Diagram 5F • STEPS 5 | 6 • Page 13). The 2 Bottom Bracket halves should fit snugly together around the bottom section of the Port Tube. Attach the Bottom Bracket halves to the bottom of the Port Tube, making sure the two round grooves [Snap-Fit Latches] on the bottom of the Port Tube are facing outwards & away from the Subwoofer (See Diagram 5F • STEP 5 • Page 13). Simultaneously connect the Bottom Bracket halves together and into the Subwoofer, by inserting 4 Type B Screws (Phillips Pan Head), into the screw holes on top of the bracket, and tighten the 4 screws, downwards into the Subwoofer unit (See Diagram 5F • STEP 6 • Page 13).

See Diagram 5D on Page 10, on adding Polyurethane Sealant, as recommended.

Now, the Square Sleeve should slide smoothly over the Mid Bracket and Bottom Brackets, & the Port Tube, into the Port Hole Base of the Subwoofer. Ensure the 2 punched holes at the bottom of the sleeve align with the 2 round grooves [Snap-Fit Latches], on the base of the Bottom Bracket on the Subwoofer (See Diagram 5F • STEPS 7 | 8 | 9 | 10 • Page 14). Once the sleeve slides down far enough, the 2 Snap-Fit Latches will snap & grip the sleeve. Now, use the 8 Type A Screws (Phillips Flat Head), included in the packaging, with a Phillips screw driver to secure the sleeve to the bracket structure. (See Diagram 5F • STEP 10 • Page 14).

DIAGRAM 5F. SQUARE SLEEVE ASSEMBLY

SQUARE SLEEVE ASSEMBLY: MID BRACKET

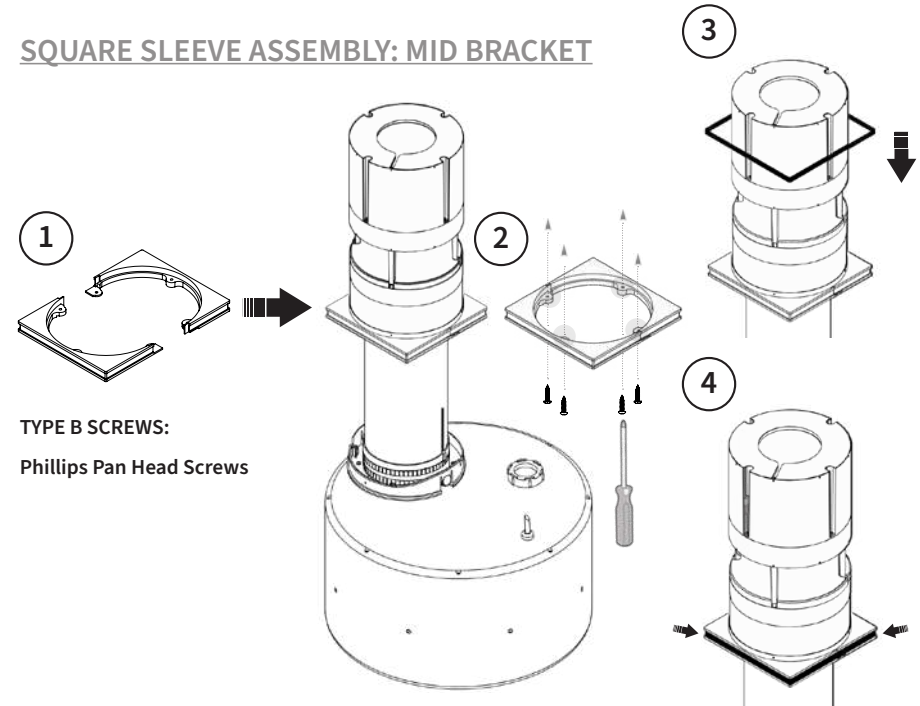

SQUARE SLEEVE ASSEMBLY: BOTTOM BRACKET

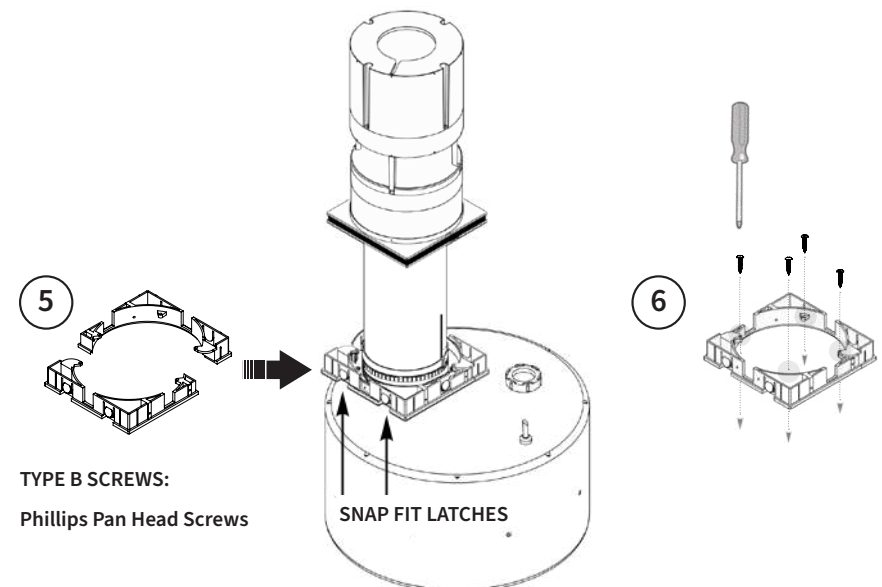

SQUARE SLEEVE ASSEMBLY: SCREW ATTACHMENT

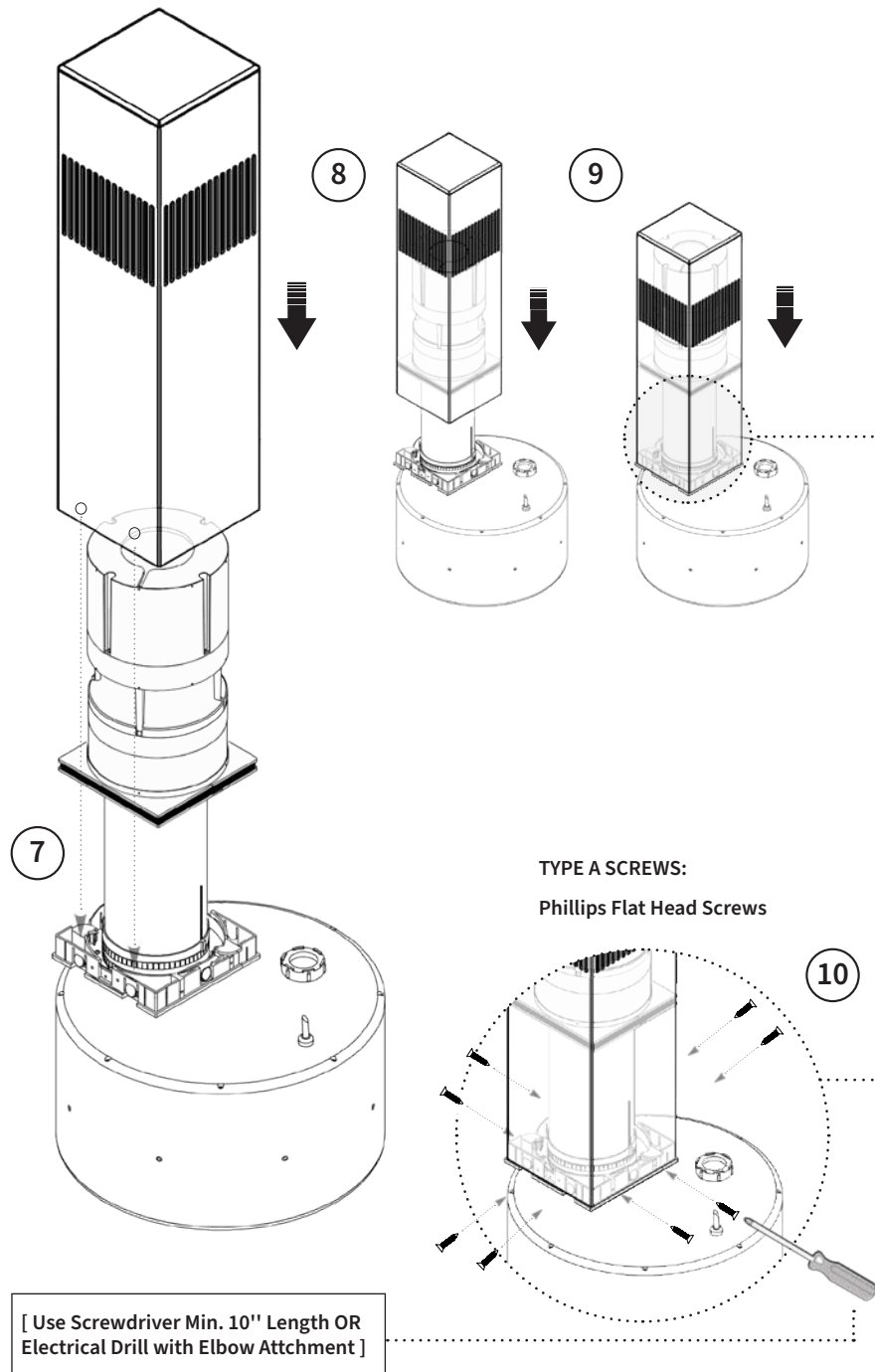

6. SYSTEM LAYOUT

Placement of the speakers throughout the home's exterior will depend on a couple of factors. The first is how uniform of a sound field is required. The laws of physics dictate that the further the listener is from the sound source the lower the apparent sound pressure level or "volume." Because of this there will always be areas with less sound and others with more. A greater number of speakers in the system will always make for more even coverage. The second factor is the desired maximum sound pressure required. Some systems are designed for background or ambient music only, while others are designed to rock the house or provide dance music. Again, the number of speakers will affect the maximum output. Consider creating different zones where louder music is required in one area and softer music in others.

The Bollard also has two dispersion options. One is omnidirectional allowing sound to be projected 360 degrees from the enclosure. The second is accomplished with an insert to limit the sound to half of the dispersion or 180 degrees from the enclosure. This is perfect for border areas where you are concerned about unwanted sound spilling into a neighbor's yard or an area where the music is simply unwanted. The Bollard must be ordered in one of the two configurations as the insert must be installed at the factory. Changing the insert in the field is not an option as doing so would likely damage the unit.

If you are concerned about determining speaker placement, Origin Acoustics offers a free design service to help you map the optimal speaker placements as well as recommended amplifier power and project scale.

Email: info@ambisonicsystems.com for more information.

7. INSTALLATION GUIDANCE

Once coverage and sound pressure requirements have been determined the Bollard locations can be selected. Before digging, confirm there are no subterranean obstructions such as water or gas lines, sprinkler pipes or electrical conduits. Holes for the subs should be deep enough to cover the entire lower section of the enclosure with approximately 1-inch of dirt on top of that section. This will allow the pillar (shell) to protrude about 18-inches above the surface.

7A. DRAIN PLUG

The Ambisonic Bollard loudspeaker comes with a drain plug inserted at the bottom of its subwoofer enclosure. If there is water ingress for any unavoidable reason, removing the drain plug will allow for water to drain out. The drain plug is easily removable with a utility knife.

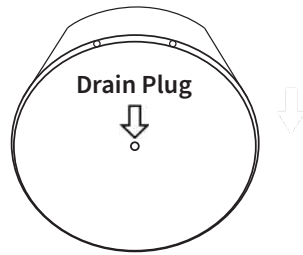

OPTION 1 – DRAIN PLUG REMAINS IN THE SUB ENCLOSURE

This option is recommended:

- In applications where ground water is at shallow depths and expected to rise easily above ground level or areas with overall very wet soil.
e.g. Areas of Houston, Louisiana

Follow the below instructions:

For Bollard with drain plug inserted

- Dig a hole for the subwoofer, about 24" in diameter and 19" deep.
- Place the subwoofer as level as possible and not tilted.
- Take care to fill empty spaces around drain hole where water might accumulate.
- The subwoofer shouldn't be in contact with large rocks or large empty holes below the drain hole.
- Use 2" of loose dirt to cover the top of subwoofer enclosure.

OPTION 2 – REMOVE THE DRAIN PLUG

This option is recommended:

- In applications with dry soil where occasional water may accidentally enter the enclosure. Use of gravel and sand will allow any water that gets into the sub enclosure to properly escape.
e.g. Las Vegas, Inland Southern California, Southwest desert

Follow the below instructions:

For bollard with drain plug removed.

- Dig a hole for the subwoofer, about 24" in diameter and 19" deep.
- Lay gravel rock (3/8" size recommended) for a depth of min. 3" below the bottom of subwoofer enclosure.
- Place the subwoofer as level as possible and not tilted.
- Take care to not block the drain hole by direct contact with gravel rock.
- Use 2" depth of loose dirt to cover the top of subwoofer enclosure.

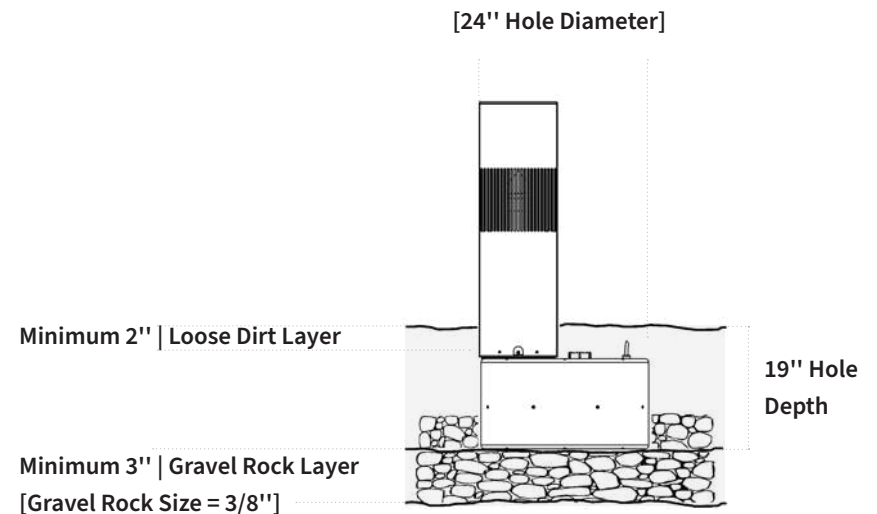

7B. BURIAL DEPTH

The subwoofer enclosure should be buried to a level where the dirt covers the wire nut and protruding wire at the top of enclosure. Do not bury excessively deep. Care should be taken to ensure that all bollards extend to the same height above ground.

NOTE: DO NOT BURY THE ENCLOSURE UNTIL ALL WIRING HAS BEEN COMPLETED.

7C. BOLLARD INSTALLATION & SPRINKLER LOCATION

It is highly recommended that the Bollard speaker be installed at a location such that the water sprinkler nearby (if any) does not spray the water jet into or +/- 2 inches from vertical slots of the bollard shell. **Follow the below illustrations:**

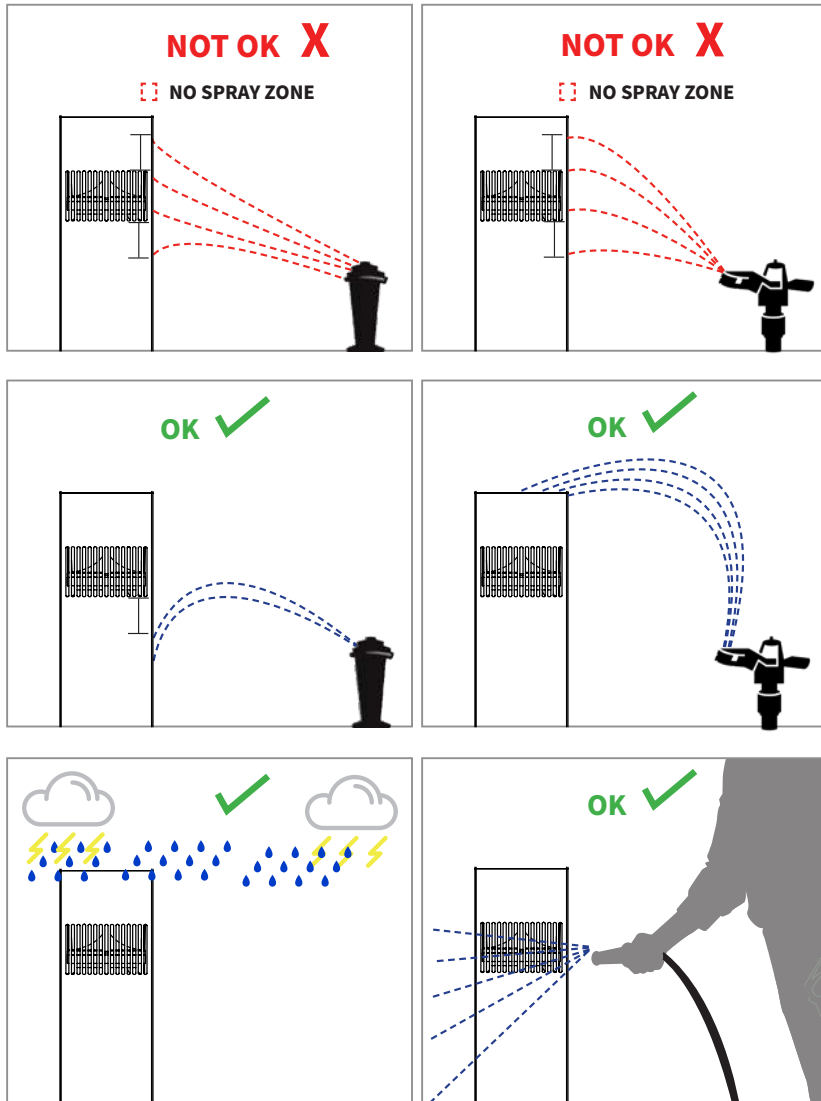

8. 70V VS 8 Ω WIRING OPTIONS

If you are looking to use more than 2 Bollard speakers, 70V WIRING SETUP is the CORRECT solution.

70V SYSTEM:
RECOMMENDED AMP: D3200 AMP
8Ω SYSTEM *:
RECOMMENDED AMP: D3200 AMP
SECOND CHOICE AMP: DSP3-700 AMP

* In the Ohm (Ω) tap switch position, the Transformers are bypassed. IN THIS SETTING, ONLY A PAIR OF BOLLARDS CAN BE USED [1 PAIR PER CHANNEL], due to the impedance in the 6 Ω (Sub) / 4 Ω (Sat) setting .

9. 70V WIRING SETUP: INSTALLATION GUIDANCE

- Use 1 separate wire run for: **Subwoofer units of Bollards**
- Use another separate wire run for: **Satellite units of Bollards**
- **The subwoofers and satellites will be run in PARALLEL for 70V WIRING SETUP.**

This means the positive connection on the amplifier will be connected to the positive connection on speaker 1, 2, 3, etc. The negative connection will be connected to the negative connections on the speakers as well. This can be accomplished with a single pair of wires in a “daisy chain” where the amplifier is at one end and the speakers are connected consecutively.

- If desired, you can also wire in a star pattern where each speaker is directly wired back to the amplifier. *Please contact the Ambisonic/Origin Acoustics Customer Service for any inquiry regarding these setups.*



RECOMMENDED D3200 AMP

AMPLIFIER OF CHOICE The D3200 amplifier from Ambisonic was specifically designed to drive Ambisonic’s speaker systems. In 70V, it is the recommended amplifier for Sub control and DSP for best performance.

The D3200 offers EQ and crossover presets specifically tailored for the Ambisonic Bollard. The presets have active crossovers that remove the bass from the satellites and send that bass only to the subwoofers. This controls more effectively how the subwoofer interfaces with the satellites: permitting you to control the subwoofer-to-satellite balance. The digital signal processing or [DSP] also shapes the sound between both subs and satellites to create optimum performance.

Firstly, Consider whether you will be running the satellites in a Mono or Stereo Setup:

In many applications, the listener will never be equidistant from a left and right speaker, so Mono may be the best option. Regardless, the D3200 offers three independent channels so both setups are viable.

Remember, you will be running four wires to each speaker, (+) and (-) for left or right, and sub.

RECOMMENDED AMP: D3200 AMP	
The D3200 Amp offers MONO or STEREO options, each using a different wiring setup:	
70V SYSTEM: 50 W TAP SWITCH SETTING	
(70V) TAP SWITCH SETTING	MAX. NUMBER OF BOLLARD SPEAKERS
50 W OPTION A: MONO SETUP	OPTION A: MONO SETUP Maximum Number: 24 Bollard Speakers per D3200 AMP - OUT 1: All SUBS (MAX 24) Channels 2/3 Bridged (OUT 3): ALL SATS - OUT 1: 1200W at 70V for all Subs Channels 2/3 Bridged (OUT 3): 1200W at 70V BRIDGED for Mono Sats
50 W OPTION B: STEREO SETUP	OPTION B: STEREO SETUP Maximum Number: 24 Bollard Speakers per D3200 AMP - OUT 1: ALL SUBS (MAX 24) OUT 2: 12 SATS PER CHANNEL OUT 3: 12 SATS PER CHANNEL - OUT 1: 1200W at 70V for all Subs OUT 2: 600W at 70V for Stereo Sats OUT 3: 600W at 70V for Stereo Sats

RECOMMENDED AMP: D3200 AMP	
The D3200 Amp offers MONO or STEREO options, each using a different wiring setup:	
70V SYSTEM: 100 W TAP SWITCH SETTING	
(70V) TAP SWITCH SETTING	MAX. NUMBER OF BOLLARD SPEAKERS
100 W OPTION A: MONO SETUP	<p style="text-align: center;">OPTION A: MONO SETUP</p> <p style="text-align: center;">Maximum Number: 12 Bollard Speakers per D3200 AMP</p> <p style="text-align: center;">-</p> <p style="text-align: center;">OUT 1: All SUBS (MAX 12) Channels 2/3 Bridged (OUT 3): ALL SATS</p>
100 W OPTION B: STEREO SETUP	<p style="text-align: center;">OPTION B: STEREO SETUP</p> <p style="text-align: center;">Maximum Number: 12 Bollard Speakers per D3200 AMP</p> <p style="text-align: center;">-</p> <p style="text-align: center;">OUT 1: ALL SUBS (MAX 12) OUT 2: 6 SATS PER CHANNEL OUT 3: 6 SATS PER CHANNEL</p>

SECOND CHOICE AMP: DSP3-700 AMP	
The DSP3-700 Amp offers MONO or STEREO options, using the same wiring setup:	
70V SYSTEM: 50 W TAP SWITCH SETTING	
50 W (70V) TAP SWITCH SETTING	MAX. NUMBER OF BOLLARD SPEAKERS
50 W MONO or STEREO SETUP	<p style="text-align: center;">Maximum Number: 24 Bollard Speakers per DSP3-700 AMP</p> <p style="text-align: center;">-</p> <p style="text-align: center;">Sub Channel: ALL SUBS (MAX 24) Left Channel: 12 SATS PER CHANNEL Right Channel: 12 SATS PER CHANNEL</p> <p style="text-align: center;">-</p> <p style="text-align: center;">Sub Channel: 700W at 70V for all Subs Left Channel: 700W at 70V for Stereo Sats Right Channel: 700W at 70V for Stereo Sats</p>
	<p style="text-align: center;">For the MONO Setting: Select the MONO DSP File For the STEREO Setting: Select the STEREO DSP File</p>

CONTACT AMBISONIC & ORIGIN CUSTOMER SERVICE FOR ANY INQUIRY REGARDING THESE SETUPS.

10A. MONO 70V WIRING WITH D3200 AMP [2 Channel Setup]

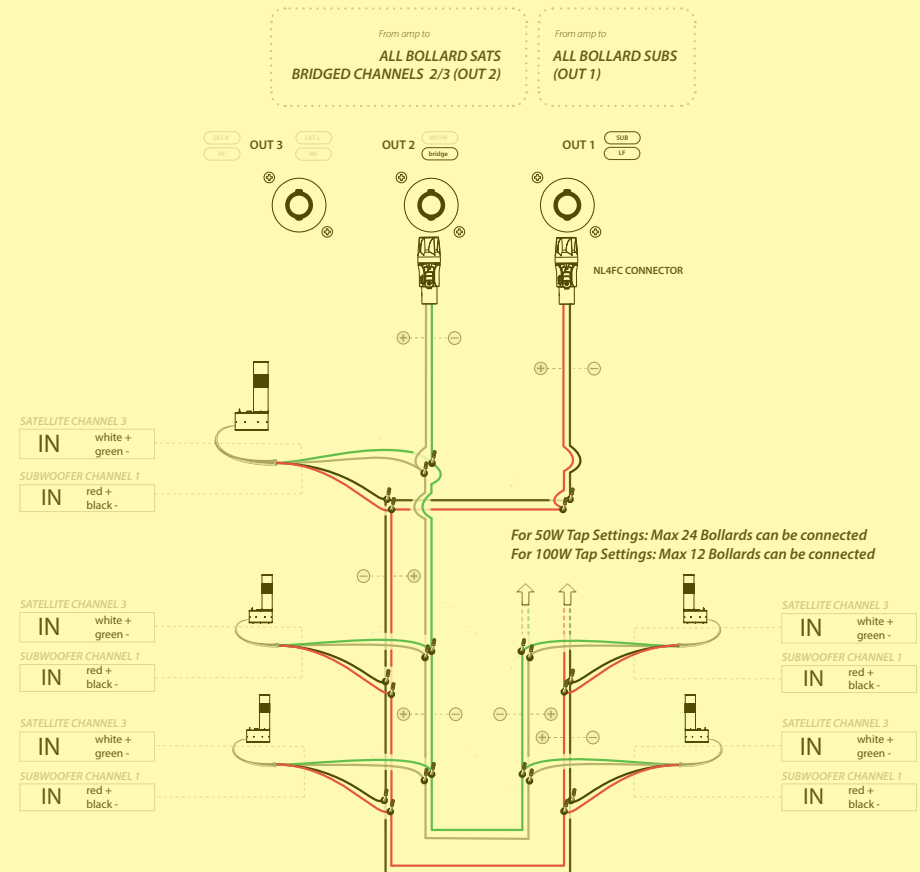

MAXIMUM NUMBER OF BOLLARDS PER D3200 AMP:
24 BOLLARDS for 50 W TAP SETTING | 12 BOLLARDS for 100 W TAP SETTING

10B. STEREO 70V WIRING WITH D3200 AMP [3 Channel Setup]

From amp to
CHANNEL 3 BOLLARD SATS (OUT 3)

From amp to
CHANNEL 2 BOLLARD SATS (OUT 2)

From amp to
ALL BOLLARD SUBS (OUT 1)

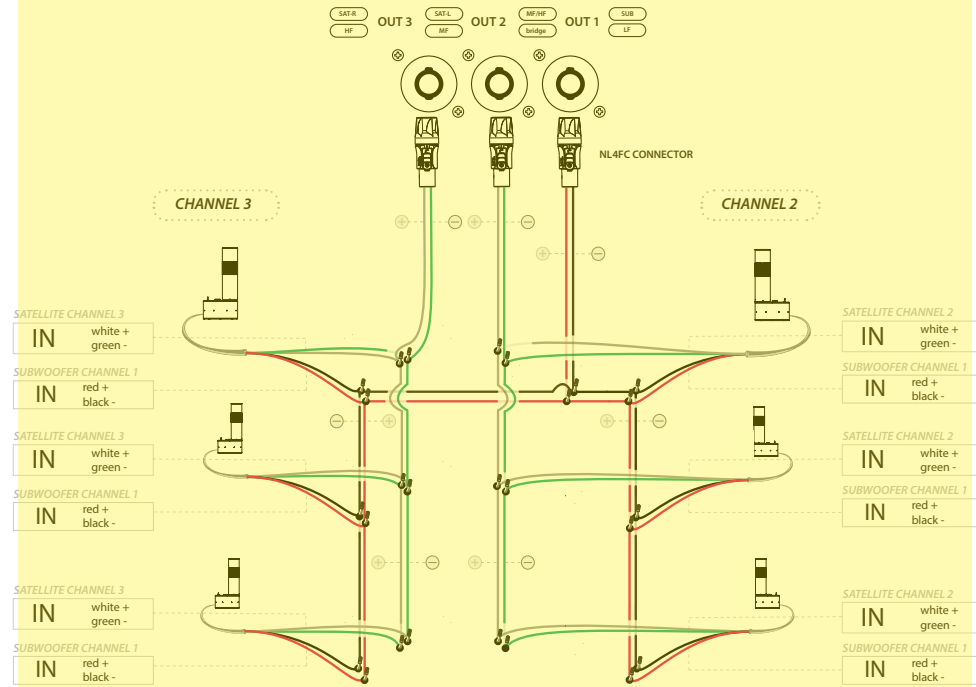

MAXIMUM NUMBER OF BOLLARDS PER D3200 AMP:
 24 BOLLARDS for 50 W TAP SETTING | 12 BOLLARDS for 100 W TAP SETTING

10C. MONO or STEREO 70V WIRING WITH DSP3-700 AMP [3 Channel Setup]

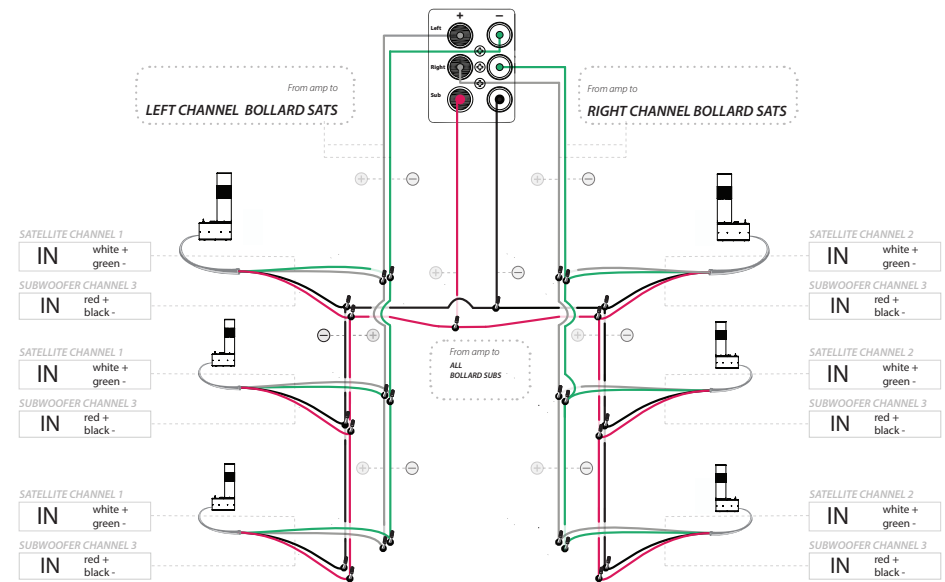

MAXIMUM NUMBER OF BOLLARDS PER DSP3-700 AMP:
 24 BOLLARDS for 50 W TAP SETTING

11. 8 Ω WIRING SETUP: INSTALLATION GUIDANCE

8Ω SYSTEM: 8Ω TAP SWITCH SETTING
RECOMMENDED AMP: D3200 AMP SECOND CHOICE AMP: DSP3-700 AMP

TAP SWITCH SETTING	AMP	MAX. NUMBER OF BOLLARD SPEAKERS
8Ω (bypass)	D3200	<p>Maximum Number: 2 Bollard Speakers per AMP in Low Impedance</p> <p>1 SAT TO OUT 2 1 SAT TO OUT 3 2 SUBS WIRED IN PARALLEL TO OUT 1 FOR 8Ω</p> <p>WARNING: RECOMMENDED TO ONLY RUN 2 (TWO) BOLLARD SPEAKERS PER AMP IN 8Ω TAP SWITCH SETTING.</p>
8Ω (bypass)	DSP3-700	<p>Maximum Number: 2 Bollard Speakers per AMP in Low Impedance</p> <p>1 SAT TO LEFT CHANNEL 1 SAT TO RIGHT CHANNEL 2 SUBS WIRED IN PARALLEL TO SUB CHANNEL FOR 8Ω</p> <p>WARNING: RECOMMENDED TO ONLY RUN 2 (TWO) BOLLARD SPEAKERS PER AMP IN 8Ω TAP SWITCH SETTING.</p>

WARNING: RECOMMENDED TO ONLY RUN 2 (TWO) BOLLARD SPEAKERS PER DSP3-700 ON 8Ω TAP SWITCH SETTING.

WARNING: IF USING MORE THAN A PAIR OF SPEAKERS, IT IS HIGHLY RECOMMENDED TO WIRE IN 70V.

These 8Ω configurations are run in a **PAIR CONFIGURATION** under the 8Ω TAP SETTING, the **Bollard Subwoofers will be wired in PARALLEL.**

Please, contact Ambisonic & Origin Customer Service for any inquiry regarding these setups.

11A. 8 Ω WIRING WITH D3200 AMP (1 BOLLARD PAIR ONLY)

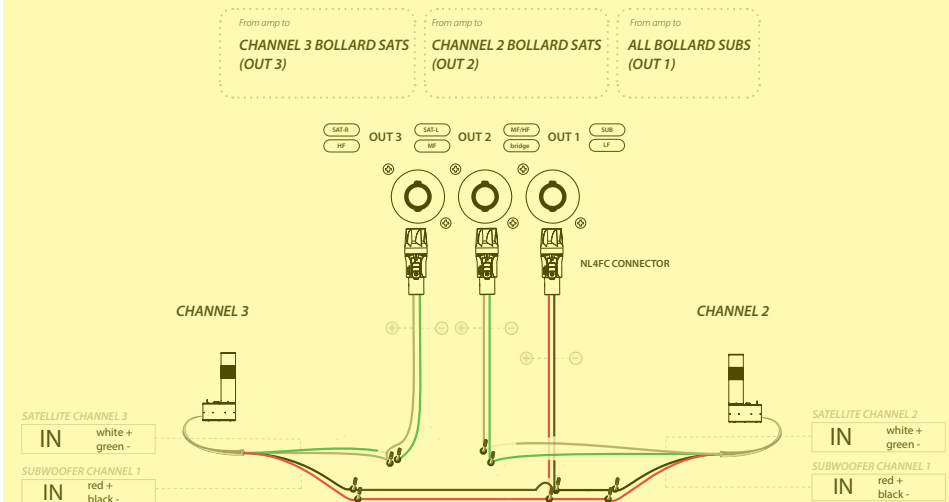

MAXIMUM NUMBER OF 2 (TWO) BOLLARDS PER D3200 AMP

*** WARNING: IT'S HIGHLY RECOMMENDED THAT ANY DESIGNS OVER 1 PAIR ARE WIRED IN 70V. RUN A MAXIMUM 2 (TWO) BOLLARD SPEAKERS ONLY PER AMPLIFIER IN 8 Ω TAP SWITCH SETTING.**

11B. 8 Ω WIRING WITH DSP3-700 AMP (1 BOLLARD PAIR ONLY)

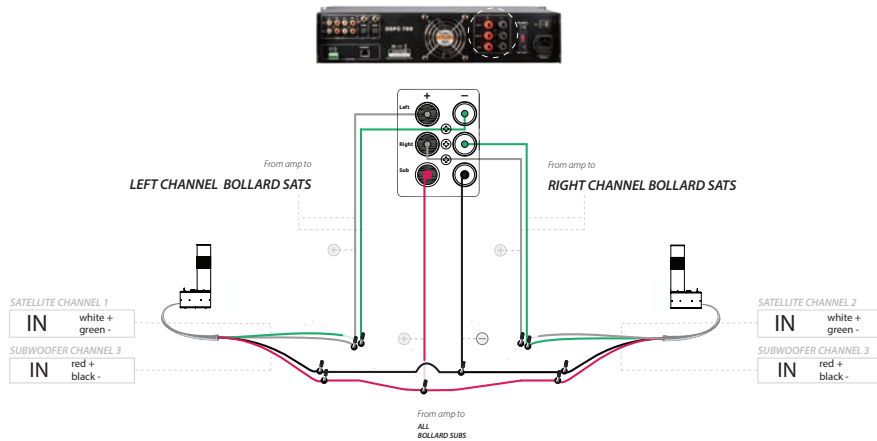

MAXIMUM NUMBER OF 2 (TWO) BOLLARDS PER DSP3-700 AMP

*** WARNING: IT'S HIGHLY RECOMMENDED THAT ANY DESIGNS OVER 1 PAIR ARE WIRED IN 70V. RUN A MAXIMUM 2 (TWO) BOLLARD SPEAKERS ONLY PER AMPLIFIER IN 8 Ω TAP SWITCH SETTING.**

12. NOTE: PAINTING THE SLEEVE

The outer sleeve (pillar) of the Ambisonic Bollard speaker is anodized specifically for achieving maximum durability of the pillar color. If you wish to change the color of the Bollard sleeve by painting, or other process, it may compromise the durability and finish of the product, compared to the original manufacturing process and modify the specifications.

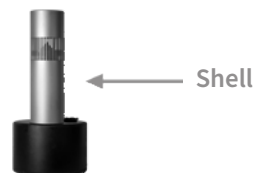

13. TROUBLESHOOTING

If you have a problem, try isolating it first. For example, if you're playing a DVD and there is no sound, try replacing the DVD with an MP3 player to see if you get sound. If it does work, then the problem is with the television, DVD player, or the cables connecting them. If it doesn't work, the problem will be with the amplifier, speakers, or those cables.

Problem	Possible Cause
No Sound	The volume may be turned down or muted. Check the volume settings on both the amplifier and the DVD player/television/computer/etc.
No Sound	Make sure the proper source is selected on the amplifier or receiver.
No Sound	Check the cord connecting the amplifier with the source. The cord may be damaged or plugged into the wrong input or output.
No Sound	Check the wires connecting the amplifier with the speakers. Make sure they're connected properly and not damaged in any way.
Poor Sound Quality	If you hear something like static, or the sound is cutting in and out, check the audio cables. If the problem increases when a cable is being moved, then the cable is most likely faulty or not connected properly.
Poor Sound Quality	Today's audio systems may have several places to adjust the volume, for example your MP3 player may have a volume control, and your amplifier may also have one. Check to be certain that the volume isn't turned up past 80% on any device.
Poor Sound Quality	Try changing sources to be certain that the selection you've chosen is a good quality recording.

14. TECHNICAL ASSISTANCE

If you have any questions or concerns about installing or using this product, you can reach us through one of the following methods:

Phone: (844) 674 - 4461

Hours of operation: 8:00am - 5:00pm (Pacific Time), Mon - Fri

Email: info@ambisonicsystems.com

If you are having technical trouble, please include the model number and briefly explain what steps you took to resolve the problem in your email, or be prepared to answer these questions over the phone. If you are considering returning the product, it's required that you contact Ambisonic prior to any return attempts. This way we can determine if the issue can be resolved without returning the product, or if needed we can provide instructions and support for the return process.

15. LIMITED 5 YEAR WARRANTY

Ambisonic warrants to the original retail purchaser only that this Ambisonic product will be free from defects in materials and workmanship, provided the speaker was purchased from an Ambisonic authorized dealer. (Note: The recommended Ambisonic D3200 amp carries a separate Limited 2 Year warranty).

If the product is determined to be defective, it will be repaired or replaced at Ambisonic's discretion. If the product must be replaced yet it is no longer manufactured, it will be replaced with a model of equal to or greater value that is the most similar to the original. If this is the case, installing the replacement model may require mounting modifications; Ambisonic will not be responsible for any such related costs.

15A. REQUIREMENTS & WARRANTY COVERAGE

This warranty may not be valid if the product was purchased through an unauthorized dealer. This warranty only applies to the individual that made the original purchase, and it cannot be applied to other purchases. The purchaser must be prepared to provide proof of purchase (receipt). This warranty will not be valid if the identifying number or serial number has been removed, defaced, or altered.

**All warranties and warranty conditions are subject to change.*

Please refer to www.ambisonicsystems.com for the latest information.

15B. NOT COVERED BY WARRANTY

- Accidental damage
- Damage caused by abuse or misuse
- Damage caused by attempted repairs/modifications by anyone other than Origin Acoustics or an authorized dealer
- Damage caused by improper installation
- Normal wear, maintenance, and environmental issues
- Damage caused by voltage inputs in excess of the rated maximum of the unit
- Damage inflicted during the return shipment

16. RETURN PROCESS

Before making any return attempts, it is required that you first contact Ambisonic. Return product to Ambisonic or your dealer, either in person or by mail. It's preferable if the product is returned in the original packaging. If this isn't possible, the customer is responsible for insuring the shipment for the full value of the product.

This warranty is in lieu of all other expressed or implied warranties. Some states do not allow limitations on implied warranties, so this may not apply depending on the customer's location. (For more information, see Magnuson-Moss Warranty Act.)



04-12-2023

6975 S Decatur BLVD, Las Vegas, NV 89118 • www.ambisonicsystems.com • 844-674-4461

©2023 Ambisonic. All copyrighted, trademarked and patented elements mentioned herein are the sole property of Ambisonic Systems.