



Immersive HD S11BP-70V Subwoofer



Model S11BP-70V Subwoofer

Description:

Ambisonic's Model S11BP-70V in-ground subwoofer is a powerhouse of clean, tight bass that perfectly compliments our Satellite loudspeakers for true outdoor distributed audio. Designed to be partially buried or as a hard-scape installation. Our proprietary 11" driver is an 8Ω, dual voice coil with a frequency response of 41Hz - 150Hz. Robust composite enclosure and powder coated canopy for "All Weather" outdoor installations.

High-performance custom built 70 volt 100 watt toroid transformers with low insertion loss and linear response for use when long wire runs or distributed audio is a requirement. The ported composite enclosure as well as all components are designed to withstand the harshest of environmental conditions in any permanent outdoor installation.

The Model S11BP-70V Subwoofer delivers the punch, impact and clean tight bass necessary for outdoor installations. The S11BP-70V is designed to be the perfect companion to our 6.5HD-AW-L high definition loudspeakers, delivering the ultimate in "High Definition" audio for any outdoor environment. Backyard landscapes, patio and pool areas will come alive with unparalleled clarity and detailed sound, engineered to give you years of satisfaction and listening pleasure.

Two 70 volt 100 watt custom toroid transformers.

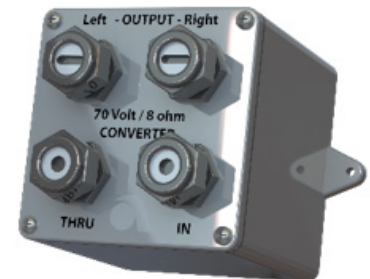

Features:

- 11" dual voice coil band-pass in-ground sub-woofer
- Direct burial 70 volt 100 watt custom toroid transformers
- Polypropylene cone
- Santoprene rubber surround
- 2" voice coil
- 61.5 Oz Y35 ferrite magnet
- 17" diameter dark brown textured canopy
- Low Density Polyethylene (LDPE) black Roto-mold sealed enclosure
- 12dB crossover network (x2)

S11BP-70V Specifications

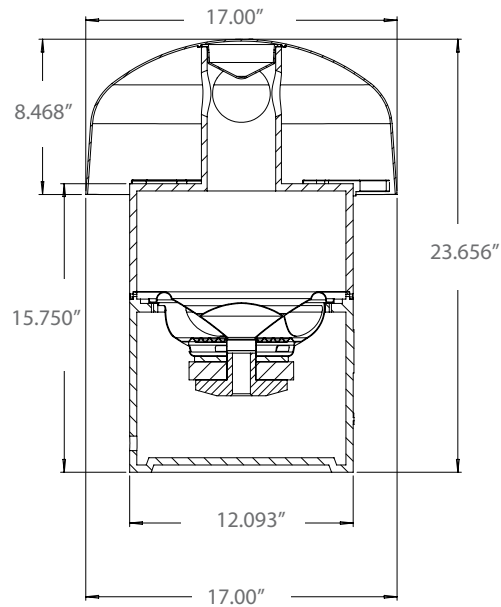

Specifications:

System Type	11" Vertical Sub-Woofer
Driver	All-weather 11" dual voice coil, polypropylene cone Woofer
Frequency Response	41 Hz - 150 Hz
Maximum SPL	113dB Continuous 119dB Peak
Sensitivity, 1m/2.83V	90db
Power Handling	200 Watts x 2 AES 400 Watts x 2 Peak
Transformer	Direct Burial 2 x 70v 100w
Input Connectors	Pigtail
Enclosure	All weather, molded composite
Dimensions, (L x Dia.)	23" H x 12.2" Diameter (Enclosure) 17" Diameter x 8.4" H (Canopy)
Shipping Weight	46.3 lbs
Warranty	Limited 3-year warranty

