



Immersive HD Model 112HD-70V



Description:

The 112HD-70V is a high definition compact subwoofer, featuring a high power 12" long throw, low frequency transducers. The uniquely braced 18mm Baltic Birch enclosure has been designed to achieve maximum extension and tight bass response.

Built-in high-performance custom built 70 volt 300 watt toroid transformer with low insertion loss and linear response for use when long wire runs or distributed audio is a requirement.

The Model 112HD-70V Subwoofer has been designed for portability as well as permanent installations with integrated 3/8-16 fly points. Engineered to compliment our model 6.5HD loudspeakers and Line Array systems. Delivering punch, high impact clean tight bass.

Weatherized Finish for protected outdoor areas is available **Model 112HD-WF-70V**

Features:

- All weather long throw woofer featuring a super stiff composite cone, large rubber surround, massive internal neodymium motor structure in a vented enclosure
- 18mm Baltic Birch enclosure
- Built in industry rated 3/8-16 fly points
- Multi position (side, top, or bottom) rubber feet for vibration free surface placement (Included)
- Integrated handles for easy transport
- All stainless-steel hardware

Applications:

- Houses of Worship
- Performing Arts Theaters
- Athletic Facilities
- Convention Centers
- Theme Parks
- Museums
- Airports & Train Stations
- Challenging Acoustic Spaces
- Multi-Purpose Venues
- Audio, Video Production

The 112HD Compact Subwoofer delivers high-output, low frequency reinforcement when space is at a premium.

70 volt 300 watt custom toroid transformer



Composite cone



Neodymium motor



Detail / Powdercoated Grill

112HD-70V Specifications

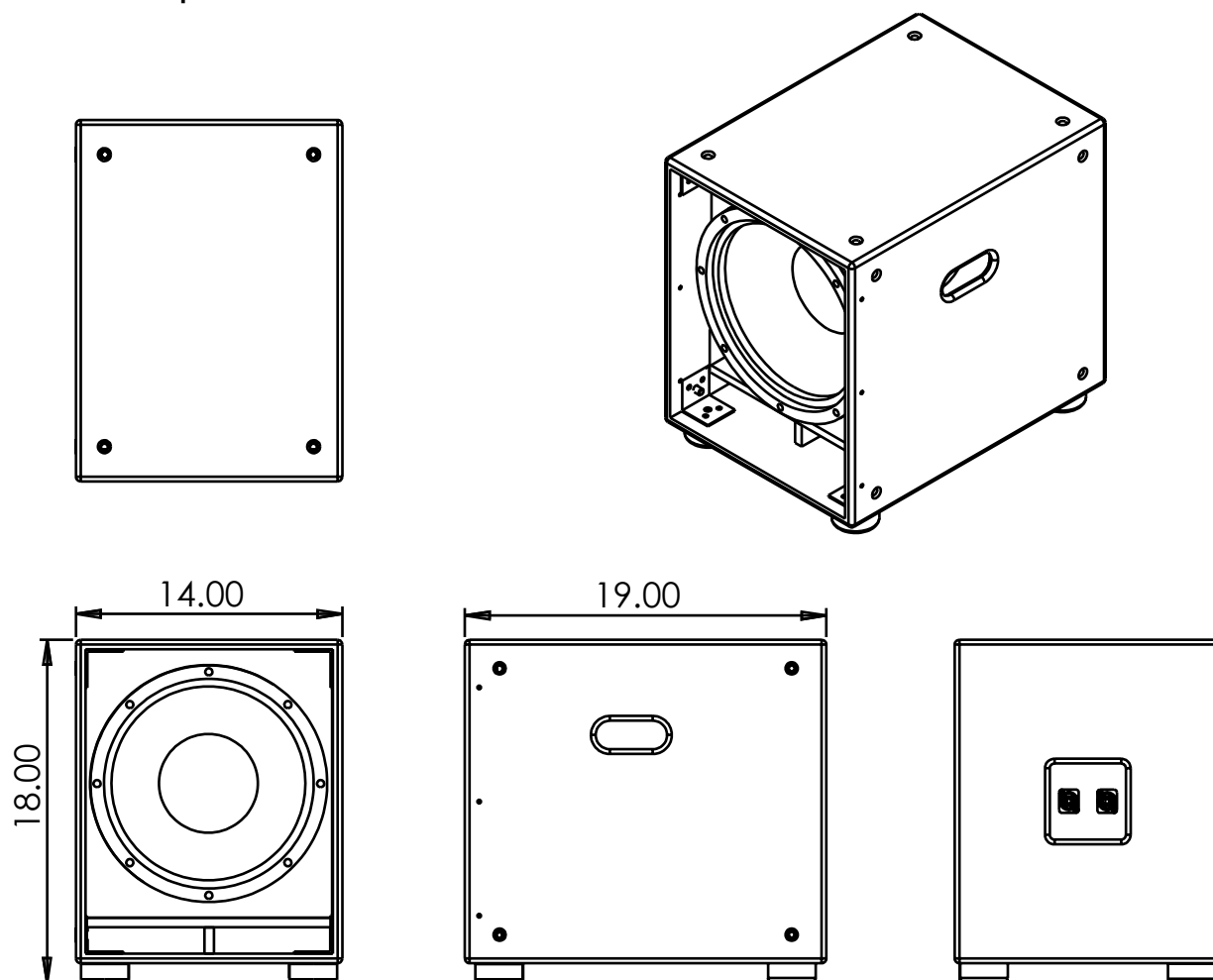

System Type	Vented alignment subwoofer
Driver Components	All-weather 12" long throw woofer
Crossover	Recommended HPF= 35hz 12db per octave Butterworth
Frequency Response	33hz - 300hz (-10db) 41hz – 300hz (+/- 3db)
Maximum SPL	123db Continuous, 129db Peak
Sensitivity, 1m/2.83V	93 dB
Power Handling	1000W AES, 4000W Peak
Transformer	70v 300w
Input Connectors	Screw terminal barrier strip / 2 x NL4 Speakon connector
Enclosure	18mm Baltic Birch, ported
Mounting	16 internal 3/8-16 fly points
Dimensions, (H x W) inches (mm)	18" (45.7cm) x 14" (35.6cm) x 19" (48.3cm)
Weight, net / shipping	60 lbs (27.2kg) / 66 lbs (29.9kg)
Warranty	Limited 3-year warranty

